



DEHN + SÖHNE

DEHN protects Medium Voltage Systems.



How to choose the right DEHNmid Surge Arrester.

There are three decisive application parameters for choosing the right DEHNmid surge arrester:

- Max. voltage U_m between the phases
- Method of neutral earthing of the medium voltage system
- Environmental conditions (e.g. pollution level) at site

The max. voltage U_m between the phases is defined as the effective value of the max. phase-to-phase voltage in an uninterferred system operation. If there are no provisions by the system management, the following flat value is assumed for U_m :

[Formula 0:]

$$U_m = 1.2 \cdot U_{L-L} \quad U_{L-L} = \text{system voltage (line-to-line voltage)}$$

The proceeding of choosing the right surge arrester can be defined in two basic steps:

Step 1:

Considering U_m and the method of neutral earthing results the max. continuous load voltage U_c the surge arrester has to be designed for. The rated voltage U_r important for the DEHNmid devices can be determined as follows:

[Formula 1:]

$$U_r = 1.25 \cdot U_c$$

According to standard IEC 60099-4, rated voltage U_r is defined as the max. permissible effective value of the ac voltage the surge arrester is designed for. This allows it to function as intended at temporary voltage rises as provided by the operating duty test procedure.

U_r defines all electrical characteristics of the medium voltage arrester.

The indication of the rated voltage is an inherent part of the type description of DEHNmid surge arresters, e.g. DMI 30 10 1 N $\hat{=} U_r = 30 \text{ kV}$.

Step 2:

The environmental conditions at site define the mechanical characteristics of the arrester. Apart from the devices for indoor application DMI ... L, there are also two types of devices for outdoor application. Types DMI ... N are designed for "normal" environmental conditions, types DMI ... H for zones with a higher pollution level.

The following will illustrate how to proceed for choosing the right medium voltage arrester according to the method of neutral earthing of the medium voltage system. There are three kinds of installation to be distinguished: line to earth, neutral to earth and line to line.

Systems with isolated neutral or earth fault neutralisation

Characteristics:

Systems with isolated neutral do not include transformer neutrals that are earthed directly or indirectly. In such kinds of network the total earth fault current can flow for a longer period of time at every earth fault. In systems with earth fault neutralisation the transformer neutrals are earthed via reactances. At earth faults within the system, the sum of the inductive currents in these earthing coils is nearly equal to the capacitive earth fault current. This leads to the extinction of arc-over earth faults.

Arrester specification:

At single-pole earth faults, the line-to-line voltage of the "sound" phases rises to voltage U_m . As the earth fault can last up to several hours, the max. continuous load voltage U_c of the arrester has to be provided to be equal to the system voltage U_m .

[Formula 2:]

$$U_c \geq U_m \rightarrow U_r \geq 1.25 \cdot U_m \quad \text{arrester between line and earth}$$

Example:

20 kV system, no defined disconnecting time
 $U_m = 24 \text{ kV}$;
 $U_r = 1.25 \cdot 24 \text{ kV} = 30 \text{ kV}$
 $\rightarrow \text{DMI 30 ...}$

If surge arresters are supposed to be used at the transformer neutral for protecting the earthing coils, these arresters have to be rated according to formula 3.

[Formula 3:]

$$U_c \geq \frac{U_m}{\sqrt{3}} \rightarrow U_r \geq \frac{1.25 \cdot U_m}{\sqrt{3}} \quad \text{arrester between neutral and earth}$$

Example:

20 kV system, no defined disconnecting time
 $U_m = 24 \text{ kV}$;
 $U_r = \frac{1.25 \cdot 24 \text{ kV}}{\sqrt{3}} = 17.33 \text{ kV}$
 $\rightarrow \text{DMI 18 ...}$

DEHN Products protect Lives and secure Material Assets.



Safety Equipment



Lightning Protection / Earthing



Surge Protection for IT Systems

New – Surge Protection for Medium Voltage Systems



Surge Protection for Power Supply Systems



Systems with isolated neutral and earth fault disconnection

Characteristics:

Beside in systems with isolated neutrals only, single-pole earth faults can also cause a rise of the voltage from line to earth in systems with isolated neutrals and earth fault disconnection. Due to the early disconnection of the earth fault, however, the max. continuous load voltage U_C on the arresters can be reduced via factor T.

Factor T is an arrester-specific value characterising the withstand capability of the arrester against temporary overvoltages U_{TOV} . The characteristics of diagram 1 show this for DEHNmid arresters.

Arrester specification:

For arresters to be installed between phase and earth results the following criterion:

[Formula 4:]

$$U_C \geq \frac{U_m}{1.25 \cdot T} \rightarrow U_r \geq \frac{U_m}{T} \quad \text{arrester between line and earth}$$

Example:

20 kV system, disconnecting time $t_d = 10$ s
 $U_m = 24$ kV; T (10 s) = 1
 $U_r = U_C = 24$ kV
 → DMI 24 ...

Arresters to be installed between the transformer neutral and earth are rated as follows:

[Formula 5:]

$$U_C \geq \frac{U_m}{1.25 \cdot T \cdot \sqrt{3}} \rightarrow U_r \geq \frac{U_m}{\sqrt{3} \cdot T} \quad \text{arrester between neutral and earth}$$

Example:

20 kV system, disconnecting time $t_d = 10$ s
 $U_m = 24$ kV, T (10 s) = 1
 $U_r \geq \frac{24 \text{ kV}}{\sqrt{3}} = 13.86$ kV
 → DMI 15 ...

Systems with low-resistance neutral earthing (earth fault factor < 1.4)

Characteristics:

Systems with low-resistance neutral earthing (solid earthing) include at least as many transformers earthed at a low resistance as to prevent the phase voltage within the entire system from exceeding factor 1.4 (earth fault factor ≤ 1.4) at earth faults.

Due to the high earth and/or short-circuit current, systems with a low-resistance neutral earthing are quickly disconnected.

Arrester specification:

For achieving a low protection level between phase and earth, it is possible to choose arresters with a low continuous voltage U_C corresponding to formula 6. The factor 1.05 used in formula 6 is a safety factor based on experience. If detailed information about the system is available, the factor can be reduced to 1.0.

[Formula 6:]

$$U_C \geq \frac{1.4 \cdot U_m \cdot 1.05}{1.25 \cdot T \cdot \sqrt{3}} \rightarrow U_r = \frac{1.4 \cdot U_m \cdot 1.05}{\sqrt{3} \cdot T} \quad \text{arrester between line and earth}$$

Example:

20 kV system, disconnecting time $t_d = 3$ s
 $U_m = 24$ kV, T (3 s) = 1.04
 $U_r = \frac{1.4 \cdot 24 \text{ kV} \cdot 1.05}{\sqrt{3} \cdot 1.04} = 19.59$ kV
 → DMI 21 ...

For arresters to be installed at non-earthed transformer neutrals, the max. continuous voltage has to be calculated corresponding to formula 7.

[Formula 7:]

$$U_C \geq \frac{0.4 \cdot U_m}{1.25 \cdot T} \rightarrow U_r = \frac{0.4 \cdot U_m}{T} \quad \text{arrester between neutral and earth}$$

Example:

20 kV system, disconnecting time $t_d = 3$ s
 $U_m = 24$ kV, T (3 s) = 1.04
 $U_r = \frac{0.4 \cdot 24 \text{ kV}}{1.04} = 9.23$ kV
 → DMI 12 ...

Systems with low-resistance neutral earthing but including system sections with earth fault factor > 1.4

Characteristics:

Not all transformer neutrals are earthed inductively with a low resistance or earthed directly. Earth faults within the system might cause the phase voltage to exceed factor 1.4.

Arrester specification:

For choosing the right arrester, the analogue proceeding is recommendable, e.g. for systems with high-resistant isolated neutrals and earth fault disconnection. Their rating for a max. continuous load voltage is determined via formula 4.

Systems with impedance neutral earthing

Characteristics:

Systems with an impedance neutral earthing are characterised by the earthing of the transformer neutrals via low-resistance earthing coils. This causes a short-circuit current at every earth fault, which is limited to max. 2 kA by the correspondingly rated earthing coils.

In case of an earth fault the voltage in the "sound phases" can rise to U_m . In case of ohmic neutral earthing the voltage can even rise to 5 % over U_m .

Arrester specification:

The following rule applies to the rating of the arresters:

[Formula 8:]

$$U_C \geq \frac{1.05 \cdot U_m}{1.25 \cdot T} \rightarrow U_r \geq \frac{1.05 \cdot U_m}{T} \quad \text{arrester between line and earth}$$

Example:

20 kV system, disconnecting time $t_d = 10$ s
 $U_m = 24$ kV, T (10 s) = 1
 $U_r = 1.05 \cdot 24 \text{ kV} = 25.2$ kV
 → DMI 27 ...

Installing arresters between phases

Characteristics:

Additionally to the arresters installed between line and earth it is advantageous for special applications to limit switching overvoltages between the three phases.

Arrester specification:

Principally there are two possibilities to limit the surges between line and earth and from line to line.

Possibility No. 1:

Installation of three surge arresters between line and earth and three arresters between the phases. All arresters have to be rated as follows:

[Formula 9:]

$$U_r = 1.25 \cdot U_m$$

The advantage of this solution, which, however, requires a lot of material, is a very low protection level in all protective circuits.

Possibility No. 2 (Neptun circuit):

One arrester between each line and a virtual neutral that is sufficiently isolated from earth. Additionally, one arrester between this virtual neutral and earth. Rating the arresters by means of

[Formula 10:]

$$U_r = 1.25 \cdot 0.667 \cdot U_m$$

leads to a protection level that is sufficient for many applications at reduced material requirements.

Choice of DEHNmid surge arresters upon system voltage, method of neutral earthing in the system and disconnecting time (t_d) from earth faults. Each arrester has to be installed between conductor and earth.

System voltage U_{L-L} [kV]	Max. voltage U_m [kV]	System with isolated neutral earthing/earth fault neutralisation	System with high-resistance isolated neutral and earth fault disconnection					System with low-resistance neutral earthing (earth fault factor ≤ 1.4)					System with impedance neutral earthing				
			$t_d = 0.1$ sec. T = 1.15	$t_d = 0.5$ sec. T = 1.10	$t_d = 1.0$ sec. T = 1.08	$t_d = 3.0$ sec. T = 1.04	$t_d = 10.0$ sec. T = 1.00	$t_d = 0.1$ sec. T = 1.15	$t_d = 0.5$ sec. T = 1.10	$t_d = 1.0$ sec. T = 1.08	$t_d = 3.0$ sec. T = 1.04	$t_d = 10.0$ sec. T = 1.00	$t_d = 1.0$ sec. T = 1.08	$t_d = 3.0$ sec. T = 1.04	$t_d = 10.0$ sec. T = 1.00		
6	7.2	DMI 9 ...	DMI 9 ...	DMI 9 ...	DMI 9 ...	DMI 9 ...	DMI 9 ...	DMI 6 ...	DMI 6 ...	DMI 6 ...	DMI 6 ...	DMI 9 ...	DMI 9 ...	DMI 9 ...	DMI 9 ...	DMI 9 ...	DMI 9 ...
10	12	DMI 15 ...	DMI 12 ...	DMI 12 ...	DMI 12 ...	DMI 12 ...	DMI 12 ...	DMI 9 ...	DMI 12 ...	DMI 12 ...	DMI 12 ...	DMI 12 ...	DMI 12 ...	DMI 12 ...	DMI 12 ...	DMI 15 ...	DMI 15 ...
15	17.5	DMI 24 ...	DMI 18 ...	DMI 18 ...	DMI 18 ...	DMI 18 ...	DMI 18 ...	DMI 15 ...	DMI 15 ...	DMI 15 ...	DMI 15 ...	DMI 15 ...	DMI 15 ...	DMI 15 ...	DMI 18 ...	DMI 18 ...	DMI 21 ...
20	24	DMI 30 ...	DMI 21 ...	DMI 24 ...	DMI 24 ...	DMI 24 ...	DMI 24 ...	DMI 18 ...	DMI 21 ...	DMI 21 ...	DMI 21 ...	DMI 21 ...	DMI 21 ...	DMI 21 ...	DMI 24 ...	DMI 27 ...	DMI 27 ...
30	36	DMI 45 ...	DMI 33 ...	DMI 33 ...	DMI 36 ...	DMI 36 ...	DMI 36 ...	DMI 27 ...	DMI 30 ...	DMI 30 ...	DMI 30 ...	DMI 31 ...	DMI 31 ...	DMI 36 ...	DMI 39 ...	DMI 39 ...	DMI 39 ...

TOV Characteristics.

The arrester-specific factor T defines the withstand capability of the arrester at upcoming increased, temporary overvoltages (U_{TOV}).

The causes for such temporary overvoltages are mostly earth faults in the system, but can also arise at unexpected load changes.

Factor T results from the ratio of temporary overvoltages and the rated voltage of the arrester ($T = U_{TOV} / U_r$) depending on the duration of the temporary overvoltage.

The duration of the temporary overvoltage is defined by the system-specific disconnection conditions.

Each of the TOV characteristics of the DEHNmid and DEHNtrack product families are indicated after pre-loading the arresters with a high current impulse of 100 kA (4/10 μ s). This preloading takes the practical performance of the arresters into account and thus increases the safety of using DEHNmid and DEHNtrack arresters.

AC voltage-time characteristics of DEHNmid arresters

Initial temperature + 60° C

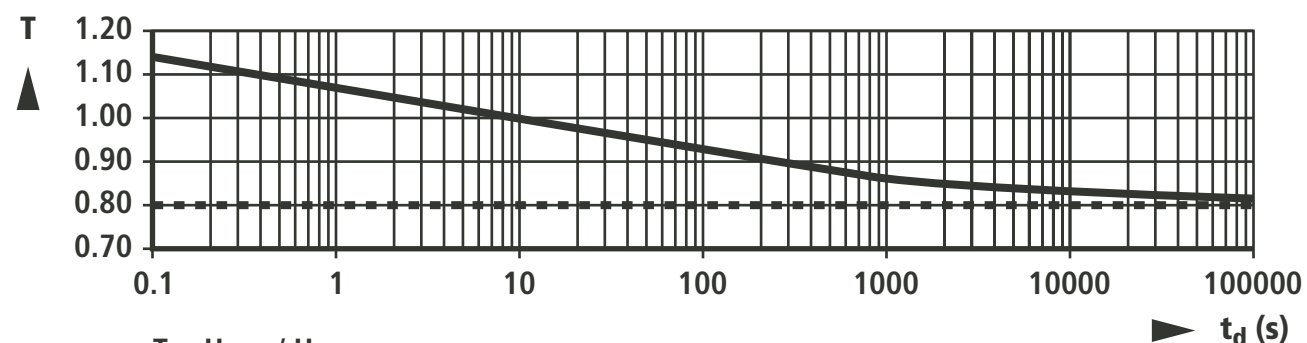

$T = U_{TOV} / U_r$
 — TOV characteristics for DEHNmid arresters (preloaded with 1 x 100 kA 4/10 μ s)
 - - - - - Continuous voltage U_c

Diagram 1

DC voltage-time characteristics for DEHNtrack arresters

Initial temperature + 60° C

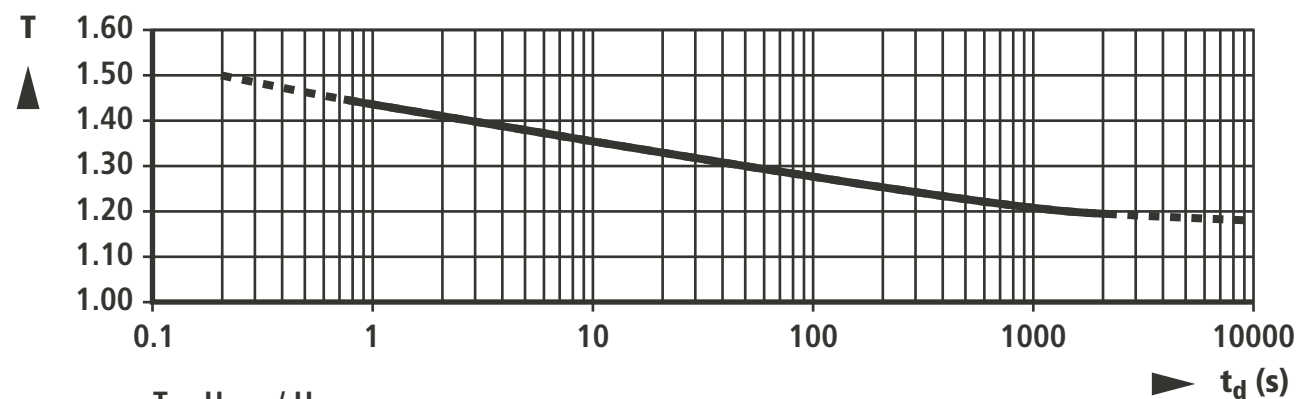

$T = U_{TOV} / U_r$
 — TOV characteristics for DEHNtrack arresters (preloaded with 1 x 100 kA 4/10 μ s)
 - - - - - Continuous voltage U_c

Diagram 2

Modular Structure of the Arrester.

The modular structures of DEHNmid and DEHNtrack arresters feature an especially high flexibility.

The arresters are dimensioned according to their rated voltage and the required creepage distance. This provides a compact structure adjusted to the respective operating conditions.

Thanks to its pregreg sheet the arresters feature a high mechanical stability and a high isolating capacity because of their enclosing silicone rubber.

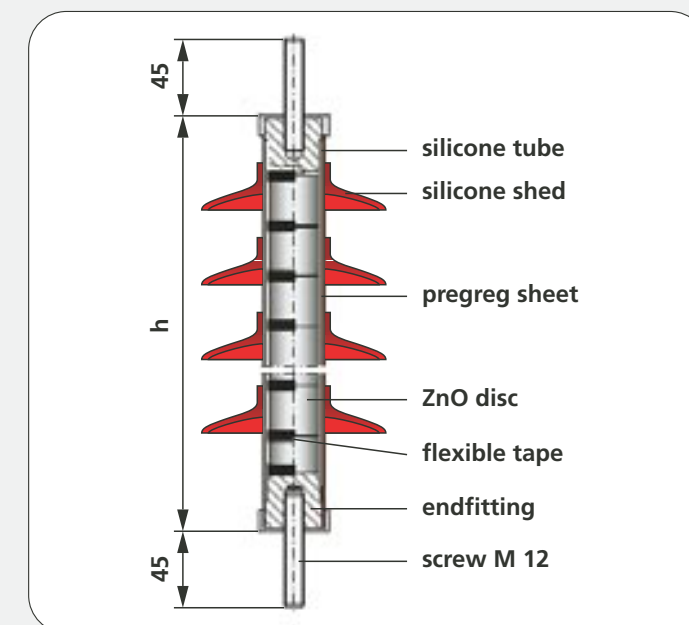

Resistant against environmental Influences thanks to Hydrophobic Silicone Enclosure.

Wherever DEHNmid and DEHNtrack arresters may be used – their resistive enclosure made of high temperature vulcanized (HTV) silicone rubber is leakproof and avoids the formation of creepage current circuits.

The unique hydrophobic characteristics of this material prevent the formation of continuous dirt and water films even under extreme environmental influences.

Even aggressive saline fog in connection with a high ambient temperature cannot affect the enclosure of the arrester or the stainless steel conductors.



Fig. 1: DEHNmid arrester with considerable salt deposits after a 5000 hours test with cyclically alternating stress including rain, saline fog, temperature fluctuations and UV radiation at a continuous voltage U_c .



Fig. 2: Regeneration of the water resistance of the arrester already some hours after the stressful 5000 hours test.



For dc voltage time characteristics, please see "Further technical information"

Nominal discharge current (8/20 μs) [I _n]	10 kA
High current impulse (4/10 μs)	100 kA
Long duration current impulse	1000 A / 2000 μs
Line discharge class	3 (6 kJ/kV _{U_p})
Mechanical shock resistance acc. to DIN IEC 68 part 2 - 29	15 g
Vibration resistance acc. to DIN IEC 68 part 2 - 6	3 g (10 - 500 Hz)
Ambient temperature [T _U]	(-55 ... +55) °C
Housing	Silicone
Colour	grey, RAL 7040
Fittings	Al alloy
Connections	clamps and screws of stainless steel

	DTR 1.2 10 3	DTR 2.4 10 3	DTR 3.6 10 3	DTR 4.8 10 3
Rated voltage dc [U _r]	1.2 kV	2.4 kV	3.6 kV	4.8 kV
Continuous operating voltage dc [U _C]	1.0 kV	2.0 kV	3.0 kV	4.0 kV
Residual voltage at 10 kA (1/2 μs) [ū _{r55}]	2.9 kV	5.5 kV	8.3 kV	10.9 kV
Residual voltage at 5 kA (8/20 μs) [ū _{r5}]	2.5 kV	4.8 kV	7.3 kV	9.5 kV
Residual voltage at 10 kA (8/20 μs) [ū _{r5}]	2.6 kV	5.0 kV	7.6 kV	10.0 kV
Residual voltage at 20 kA (8/20 μs) [ū _{r5}]	2.9 kV	5.5 kV	8.3 kV	10.9 kV
Residual voltage at 250 A (30/70 μs) [ū _{r5sch}]	2.1 kV	4.0 kV	6.1 kV	7.9 kV
Residual voltage at 500 A (30/70 μs) [ū _{r5sch}]	2.2 kV	4.1 kV	6.2 kV	8.1 kV
Residual voltage at 1000 A (30/70 μs) [ū _{r5sch}]	2.3 kV	4.2 kV	6.4 kV	8.3 kV
Insulation for arrester housing / p.f. withstand voltage (wet) [U _{nst}]	≥ 40 kV	≥ 40 kV	≥ 40 kV	≥ 40 kV
Insulation for arrester housing / switching - impulse withstand voltage (wet) [U _{nstsch}]	≥ 50 kV	≥ 50 kV	≥ 50 kV	≥ 50 kV
Height [H]	173 mm	180 mm	187 mm	193 mm
Weight [M]	3 kg	3 kg	3 kg	3 kg
Creepage distance	230 mm	237 mm	244 mm	250 mm

Ordering information				
Type	DTR 1.2 10 3	DTR 2.4 10 3	DTR 3.6 10 3	DTR 4.8 10 3
Part No.	990 301	990 302	990 303	990 304
Packing Unit / pcs	1	1	1	1

- Metal oxide arrester, line discharge class 3, for dc systems up to 4.8 kV
- Nominal discharge current 10 kA (8/20)
- High current withstand capability 100 kA (4/10)
- High temperature vulcanized (HTV) silicone enclosure avoids formation of dirt or water films
- High bending resistance and unbreakable at overloads thanks to prepreg sheet
- High durability thanks to powerful metal oxide varistors
- Mechanical shock and vibration resistance according to DIN IEC 68
- Flexible installation

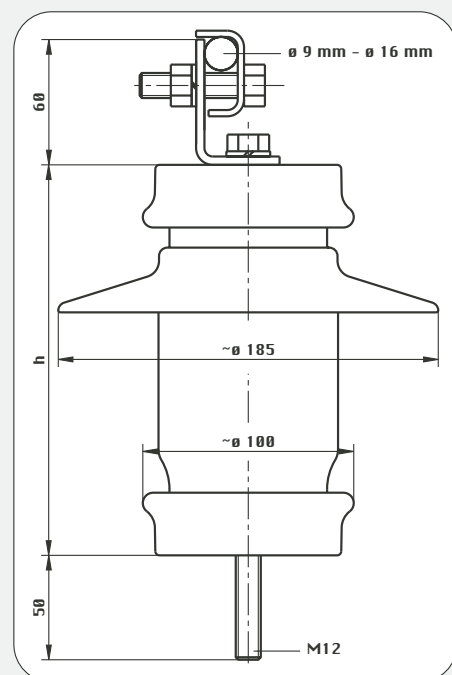

- Disconnects overloaded arresters from the system
- Prevents potential earth faults
- Ensures the faultless operation of the medium voltage system
- Spark gap/Thermal effect principle, no blasting agents
- No maintenance

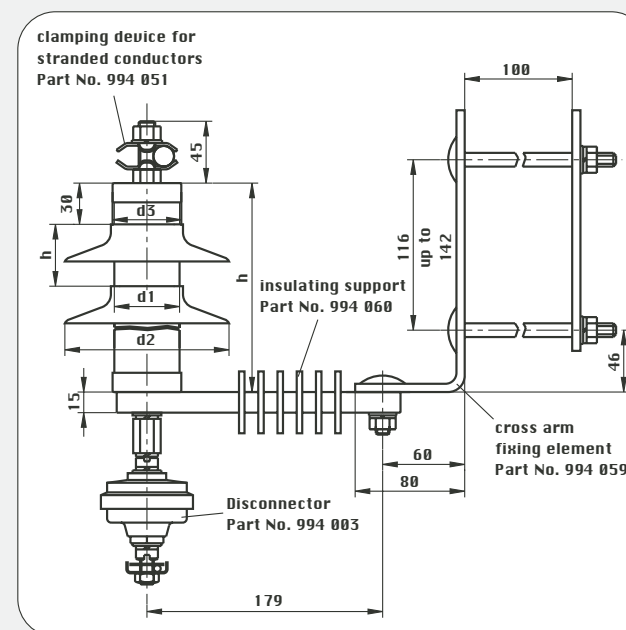
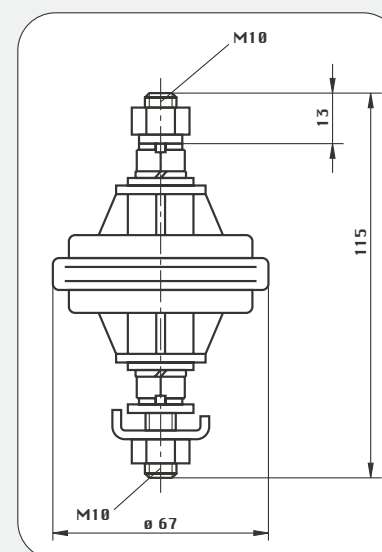

Application example: Disconnector DIC 10

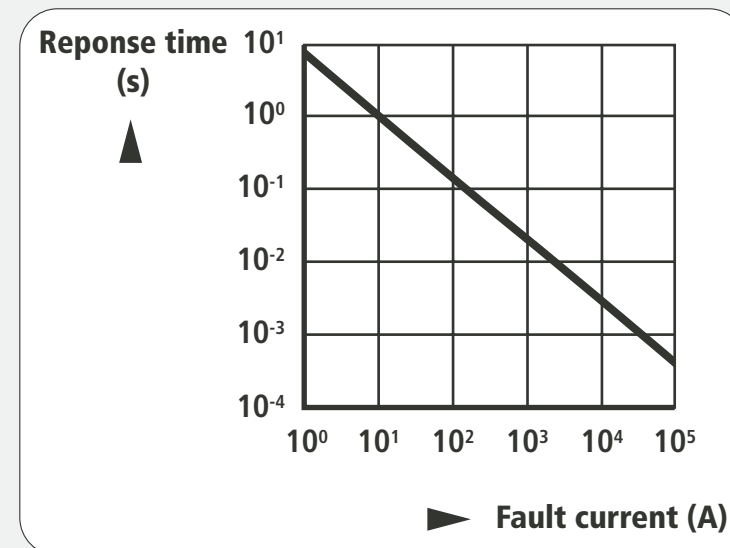

Diagram 3

DIC 10	
Weight	0.18 kg
Ambient temperature [T _U]	(-40 ... +55) °C
Altitude	up to 3000 m a.s.l.
Rated frequency [f _N]	48 Hz to 62 Hz
Response time	see diagram 3
Housing	ultra violet-stabilized low-pressure polyethylene
Colour	green
Fittings	nuts and screws of stainless steel
Conductor clamp	diameters up to 12 mm
Ordering information	
Type	DIC 10
Part No.	994 003
Packing Unit / pcs	1

Impulse Meter

IZ(M) 100: for all SPD Types



- Registration of discharges of surge arresters
- Control of the durability of the arresters by registration of leakage currents at IZM 100 impulse meter
- High current withstand capability 100 kA (4/10)
- Quick data acquisition
- Mechanically stable with aluminium enclosure
- Corrosion-resistant
- Water-proof IP 67 unit

IZM 100: Impulse meter with counter and measuring scale for recording discharge currents and registration of leakage currents

IZ 100: Impulse meter with counter for registration of discharge currents

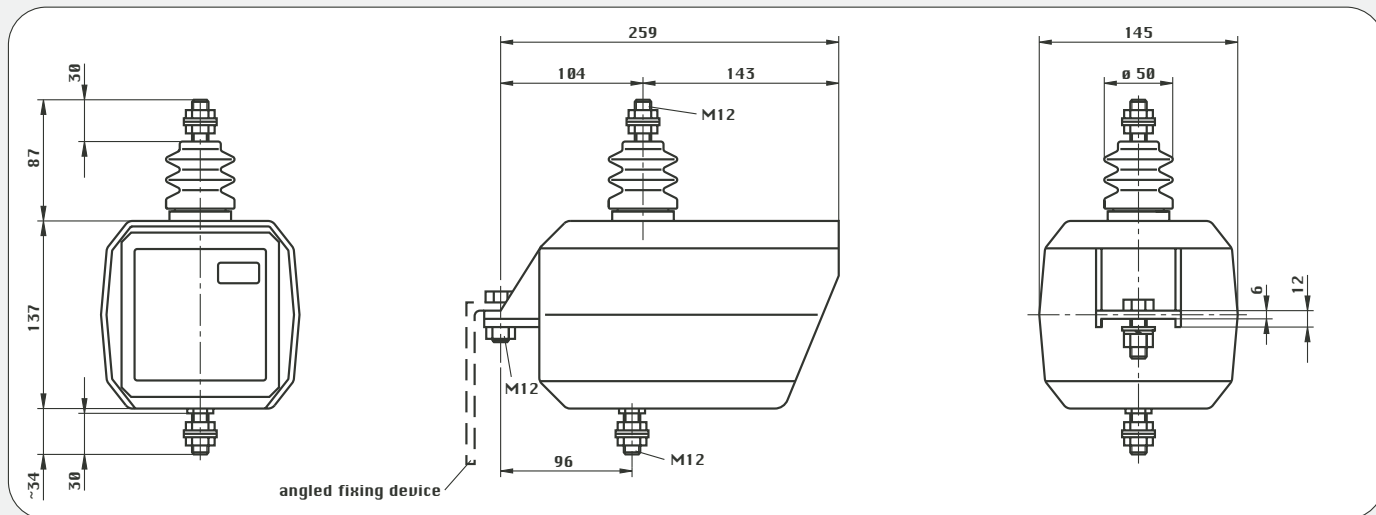

	IZ 100	IZM 100
Display-Meter	6 digit cyclometer	6 digit cyclometer
Minimum count current	200 A (8/20 μs)	200 A (8/20 μs)
Maximum high current withstand capability	100 kA (4/10 μs)	100 kA (4/10 μs)
Nominal residual voltage at 100 kA (4/10 μs)	5 kV _p	5 kV _p
Measuring scale	—	0 ... 21 mA _{rms}
Maximum count rate	min. 5 counts / sec.	min. 5 counts / sec.
Housing	Aluminium, powder coated	Aluminium, powder coated
Colour	grey	grey
Earth Connection	M12 nickel-plated brass fitted with 2 brass locknuts	M12 nickel-plated brass fitted with 2 brass locknuts
Phase Connection	M12 nickel-plated brass fitted with 2 brass locknuts	M12 nickel-plated brass fitted with 2 brass locknuts
Mounting	cast lug on the reverse side M12 or additional fixing angle	cast lug on the reverse side M12 or additional fixing angle
Ordering information		
Type	IZ 100	IZM 100
Part No.	994 001	994 002
Packing Unit / pcs	1	1



Accessories

Conductor Clamps / Fixing Elements

Conductor Clamps

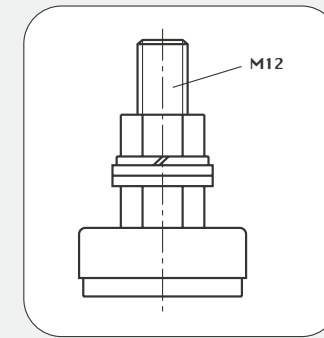

Cable lug connection
Type: KA KS
Part No.: 994 050

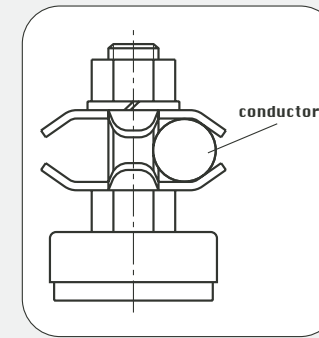

Stranded conductor clamp
up to D = 9 mm
Type: KA LS 9
Part No.: 994 051

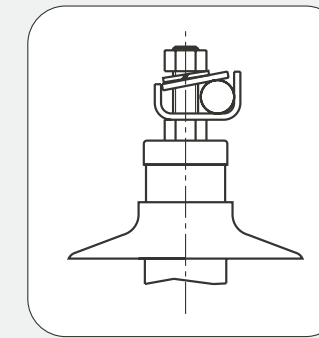

Stranded conductor clamp
up to D = 16 mm
Type: KA LS 16
Part No.: 994 052

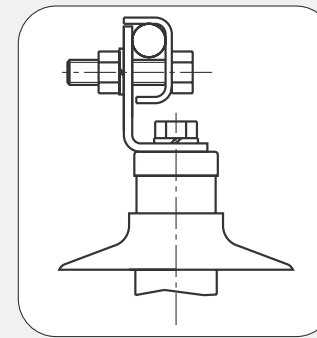

Stranded conductor clamp
for D = 9 up to 16 mm
Type: KA LS 9.16
Part No.: 994 053

Fixing Elements

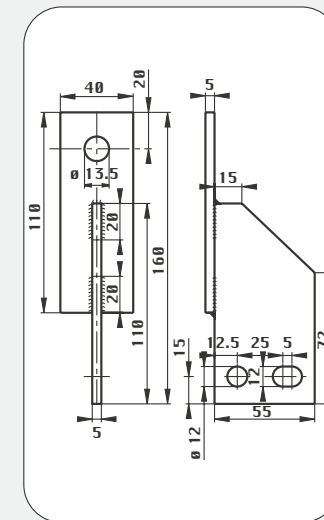

Acc. to DIN
Type: BF DIN
Part No.: 994 054

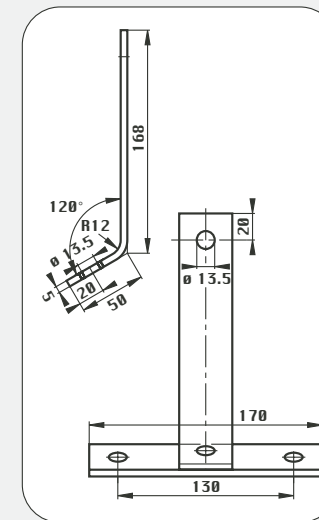

Acc. to TGL
Type: BF TGL
Part No.: 994 058

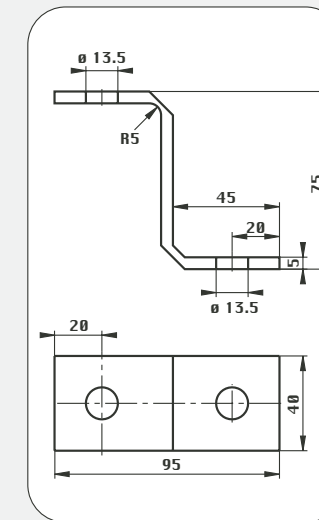

Angled fixing element
Type: BF WI
Part No.: 994 055

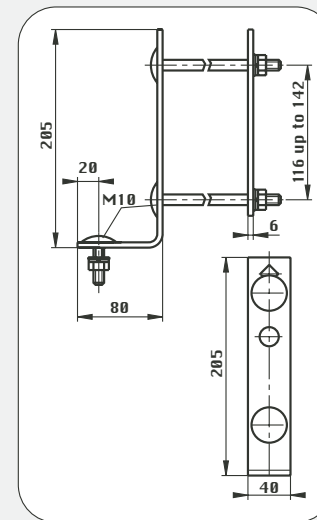

Cross-arm-fixing element
Type: BF TRA
Part No.: 994 059

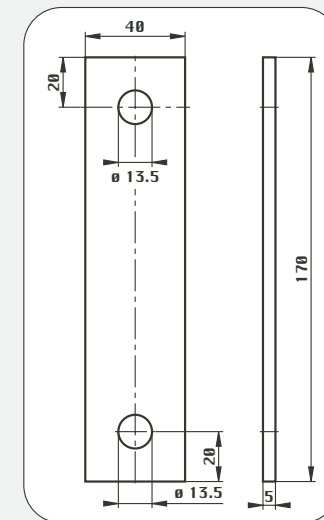

Acc. to NEMA
Type: BF NEMA
Part No.: 994 056

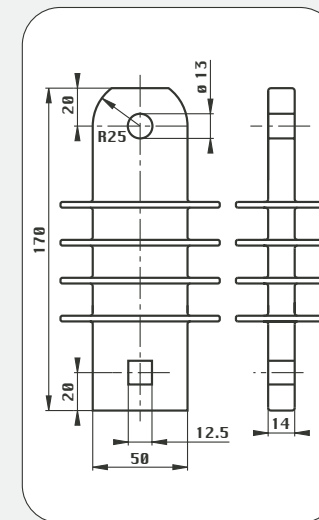

Insulating support
Type: BF IH
Part No.: 994 060

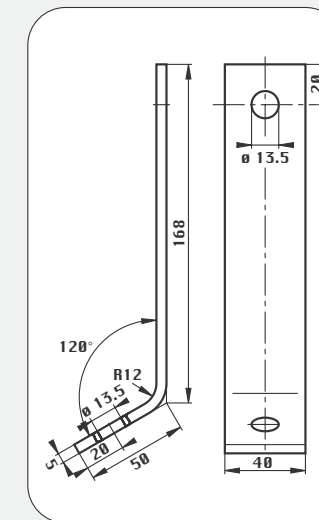

Wall fixing element
Type: BF WA
Part No.: 994 057



DEHN + SÖHNE

More Information

I would like to have more information about the following topics:

- Main Catalogue "Surge Protection"
- Main Catalogue "Lightning Protection"
- Main Catalogue "Safety Equipment"
- Main Catalogue **DELTEC**® Safety Equipment
- Seminars
- Please arrange for a visit of one of your Sales Engineers (by appointment)

Name

Company

Address

Country

Phone/Fax

eMail

Please fill in and send to us!

Lightning Protection
Surge Protection
Safety Equipment

DEHN + SÖHNE
Hans-Dehn-Str. 1
P.O. Box 1640
92306 Neumarkt
Germany

Tel. +49 9181 906-0
Fax +49 9181 906-100
www.dehn.de
info@dehn.de

